

DU-DD1-12

JEFA 12V DIRECT DRIVE UNIT

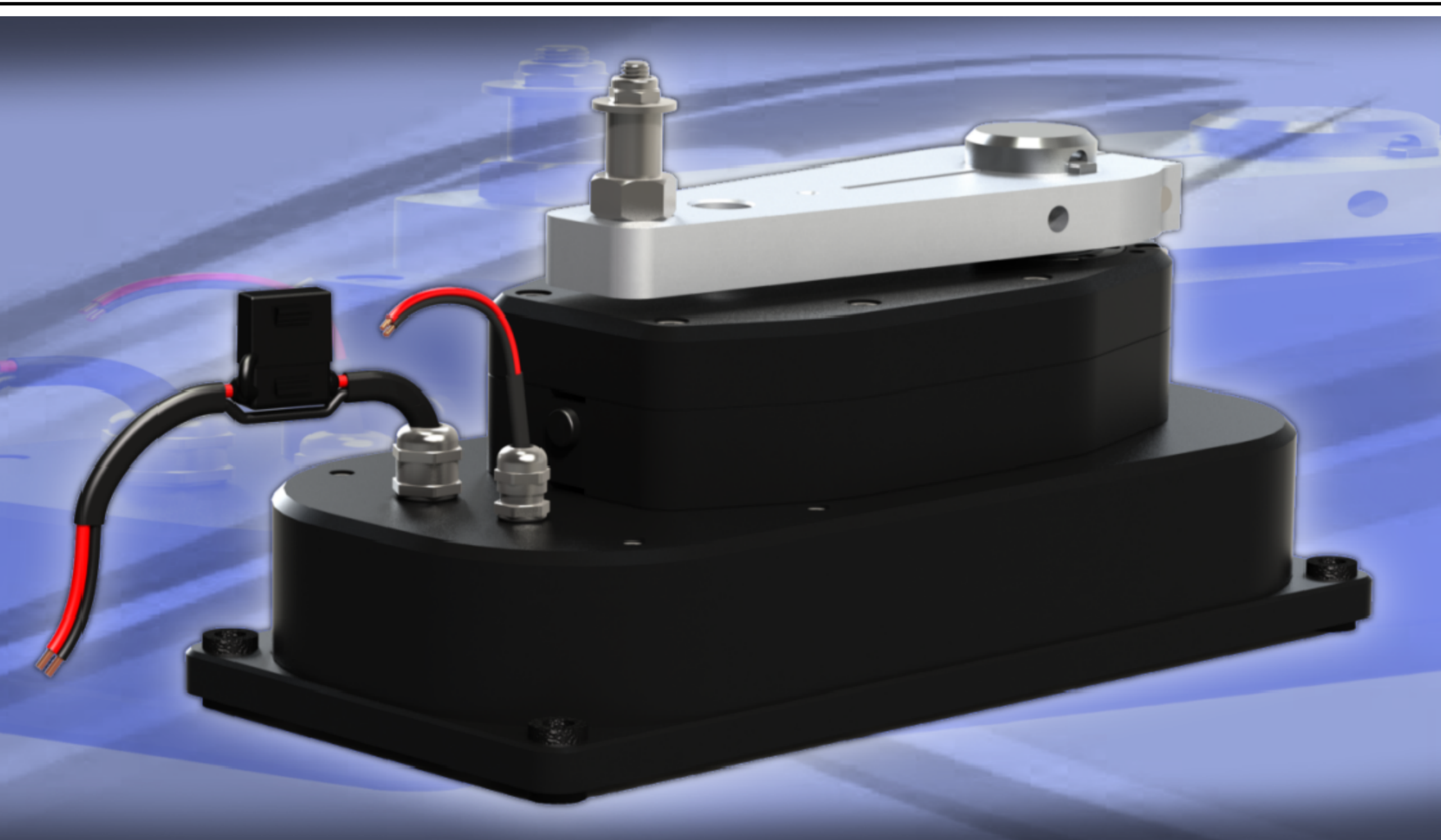

- **Part list**
- **Exploded view**
- **Replacement parts/Accessories**

DU-DD1-OL

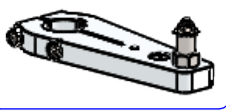

Z8-4142A



Z8-4145 complete



Z8-4137-4138



DU-COSET-12

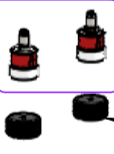

DU-DD1-MOR



Z8-4155 complete

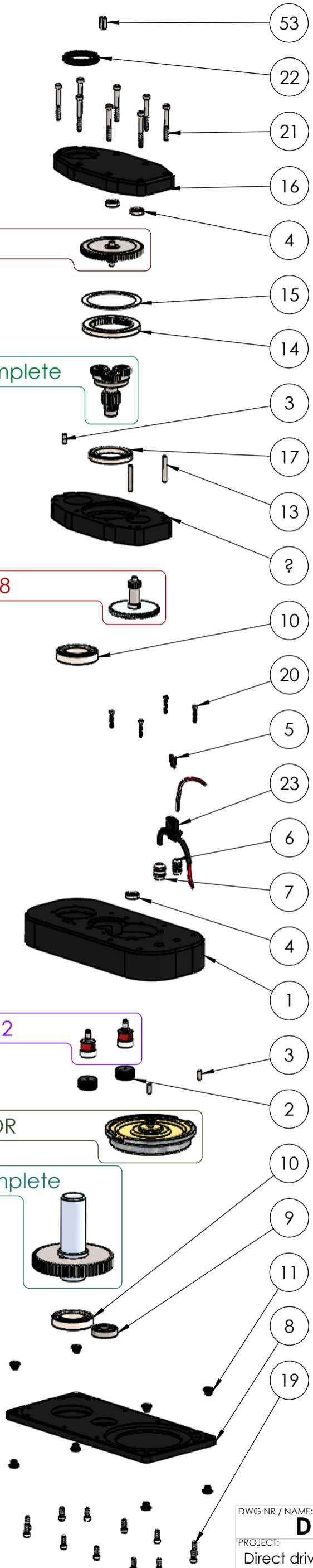
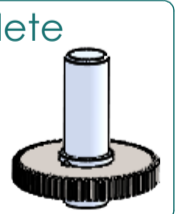

ITEM NO.	PART NUMBER	QTY.
1	Z8-4102 gear house	1
2	Z8-4175 Cluch stopper delrin ø30x16,5	2
3	Z-DIN0007-06x16 Cylindrisk A2 stift 6x16mm	3
4	ZBB-608 ballbearing 2RS 8x22x8mm	3
5	Z-EL109 Automotive fuse 10Amp RED	2
6	Z-EL140 Messingforskruing HKS 12x1,5	1
7	Z-EL141 Messingforskruing HKS 16x1,5	1
8	Z8-4105 Bottom plate	1
9	ZBB-6004 ballbearing 2RS 20x42x12mm	1
10	ZBB-6008 ballbearing 2RS 40x68x15mm	2
11	Z8-4190 Rubber washer	8
12	Z8-4111 Middleplate	1
13	Z-DIN0007-06x45 Cylindrisk A2 stift 6x45mm	2
14	Z8-1009 - Inner gear Z70 M1	1
15	Z8-4117 Lockring for plane gear	1
16	Z8-4121 Topplate	1
17	ZBB-61811 ballbearing um 55x72x9mm	1
18	Z-FED08x08x24	1
19	Z-DIN0912-M06x16 Hexagon socket head screw CH A2 M6x16	12
20	Z-DIN0912-M04x25 Hexagon socket head screw CH A2 M4x25	4
21	Z-DIN0912-M06x55 Hexagon socket head screw CH A2 M6x55	8
22	ZP2-406007 Lipseal ø40xø60x7mm	1
23	Z-EL116 House for automotive fuse	1

ITEM NO.	PART NUMBER	QTY.
24	Z8-4160 Output lever	1
25	Z4-225 Pin for output lever M18x1.5 ø16	1
26	Z-DIN0912-M10x60 Hexagon socket head screw CH A2 M10x60	2
27	Z-DIN0985-M08 Locknut A2 M08	1
28	Z-DIN9021-M08 Washer for 8mm shaft	1

ITEM NO.	PART NUMBER	QTY.
29	Z8-4141 Shaft with Z14 M1	1
30	Z8-4143 M1 Z101	1

ITEM NO.	PART NUMBER	QTY.
31	Z8-4145 Shaft for planet gear	1
32	Z8-1105 - 10mm shaft for step3	3
33	Z8-1130 Washer ø10xø16x1 polycarbonat	6
34	Z8-1010 - Gear wheel Z28 M1	3
35	Z8-1112 Teflon bearing ø10xø12x10mm	3
36	Z-DIN0988-10x16x0.2	3
37	Z-DIN0471-A10 Lockring outside A10 DIN471	3
38	ZBB-608 ballbearing 2RS 8x22x8mm	1

ITEM NO.	PART NUMBER	QTY.
39	Z-DIN1481-04x24 Spring Pin Slotted A2 4x24mm	1
40	Z8-4138 M1 Z19	1
41	Z8-4137 Gear wheel M1 Z79 V15dg	1

ITEM NO.	PART NUMBER	QTY.
42	Z8-1008 12 Coil spole PETP	2
43	Z8-1135 Lock for spule	2
44	Z8-1106 - Clutch shaft	2
45	Z8-1114 - Spring for Clutch	2
46	Z8-1107 - Clutch iron bush	2
47	Z8-1015 Magnet N30 20x6mm forniklet	2

ITEM NO.	PART NUMBER	QTY.
48	Z8-4132 Golden motor	1
49	Z8-4130 Gear wheel M1 Z15 H15dg	1

ITEM NO.	PART NUMBER	QTY.
50	Z8-4155 Gear wheel M2 Z65	1
51	Z8-4150 Outputshaft	1
52	Z-DIN0471-A45 Lockring outside A45 DIN471	1
53	Z-FED08x08x20	2

DWG NR / NAME: **DU-DD1 / Autopilot drive exploded view** BATCH NR:

PROJECT: Direct drive unit REKV.NR / ORDRE NR:

DATE: 05-01-2009 NAME: KJ SCALE / PAPER: 1:7 / A3 MATERIAL: LOCATION: ORDRE DATO:

MODIFY DATE: WEIGHT: g REV: LEV.DATO:

JEFA STEERING ApS
 AGENAVEJ 43
 2670 GREVE. DENMARK
 Tlf: +45 4615 5210 & Fax: +45 4369 5211
 Email: info@jefa.com www.jefa.com

DU-DD1-OL
Output lever for DU-DD1 including Ø16mm pin

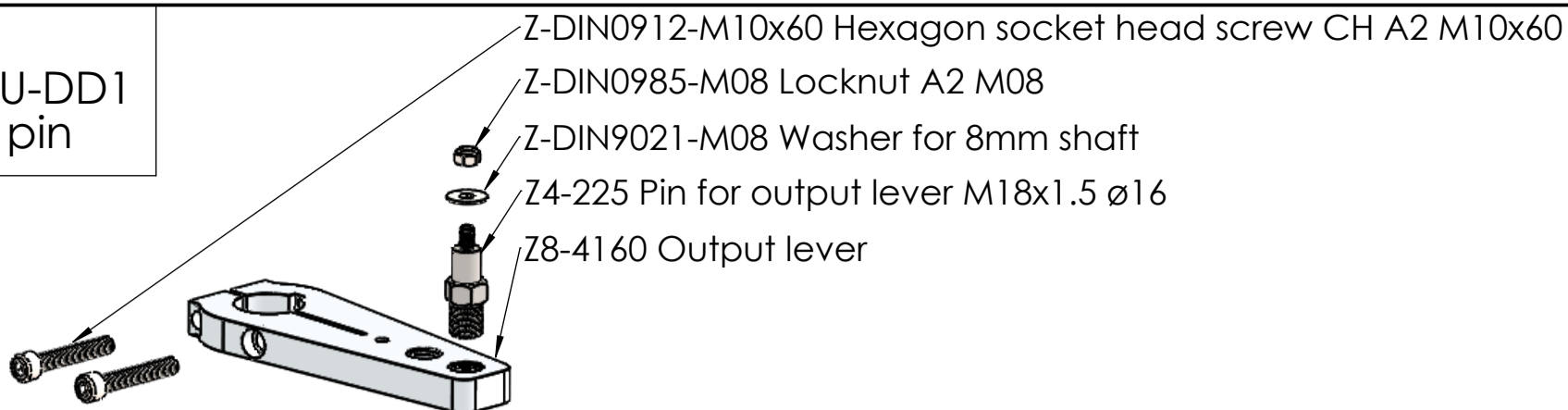
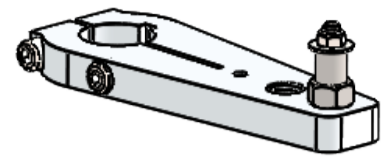

Z8-4142A
Replacement kit with welded shaft and gear

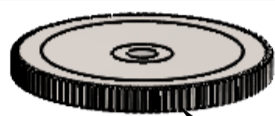
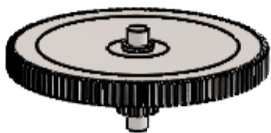

Z8-4143 M1 Z101
Z8-4141 Shaft with Z14 M1

Z8-4145 complete
Complete planet gear rep-kit with welded shaft, bearings and gearwheels

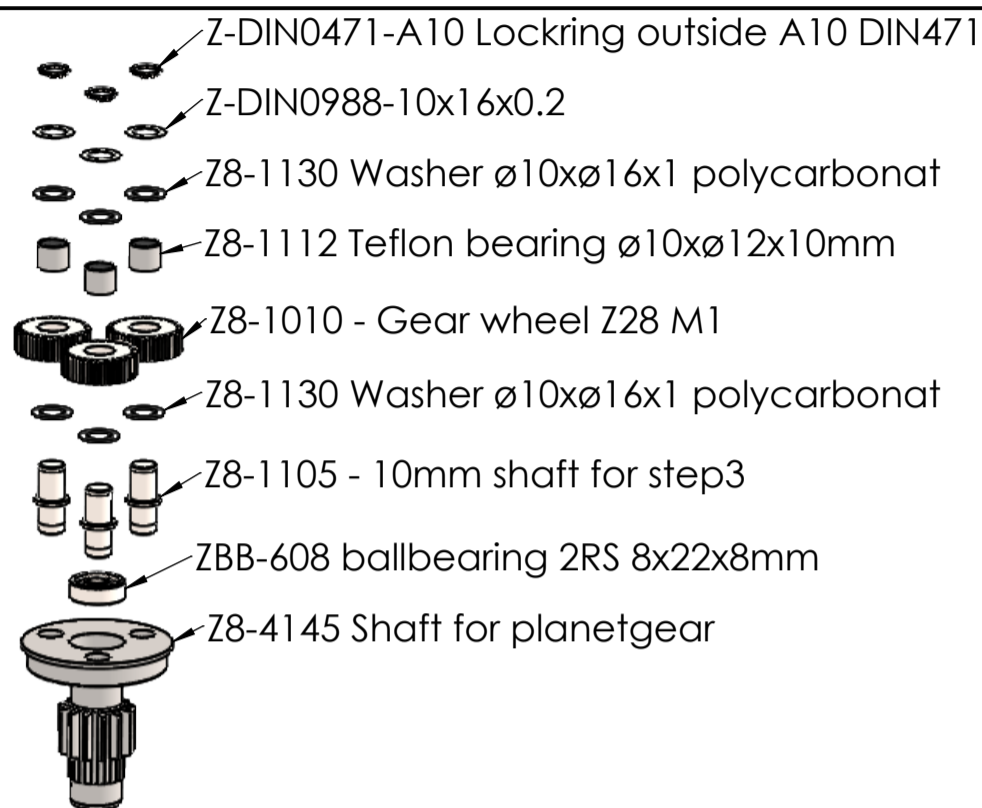
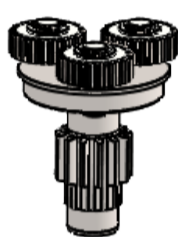

Z8-4137/4138
Replacement kit with assembled shaft and gear

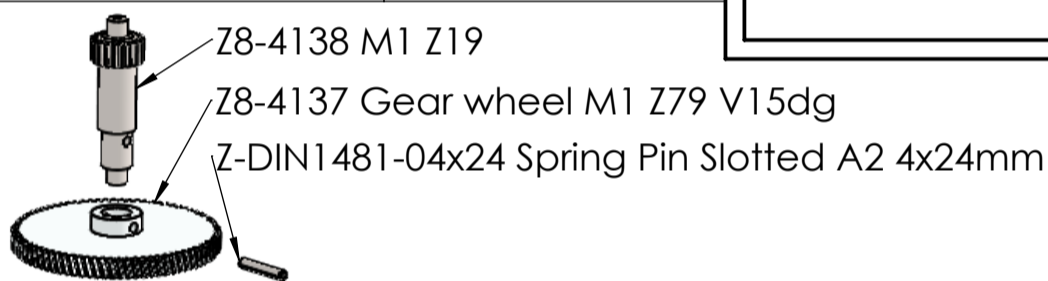

DU-DD1-MOR
Motor rep-kit retro fit

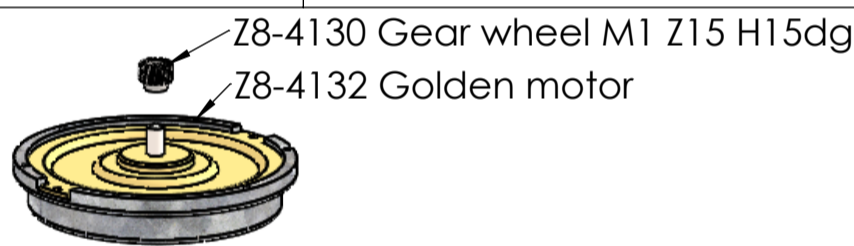
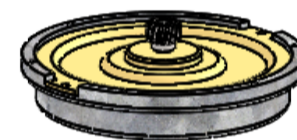

Z8-4155 complete
Gear wheel rep-kit mounted on output shaft

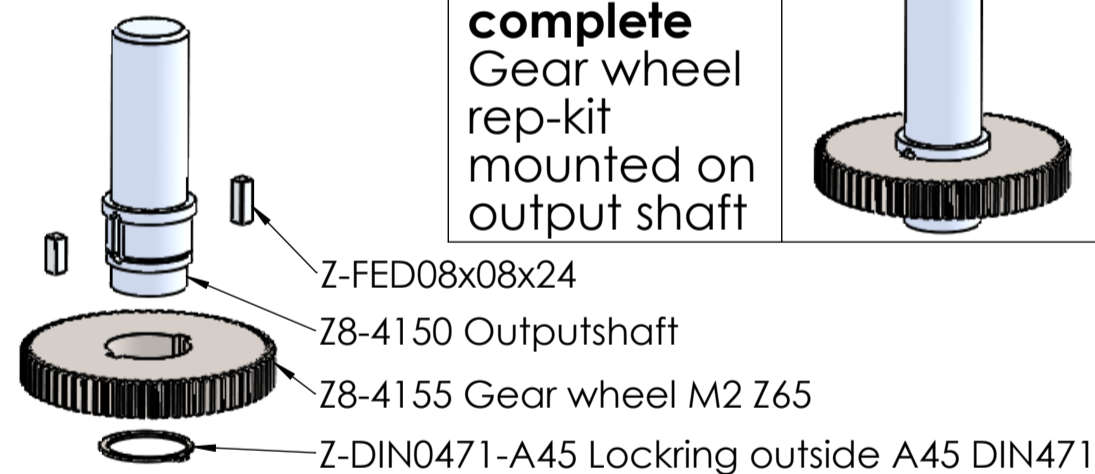
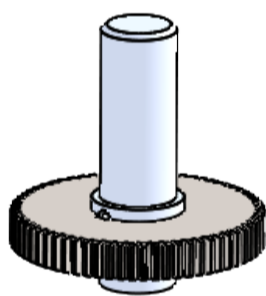

DU-CLUTCH
Clutch pin set including magnet and springs

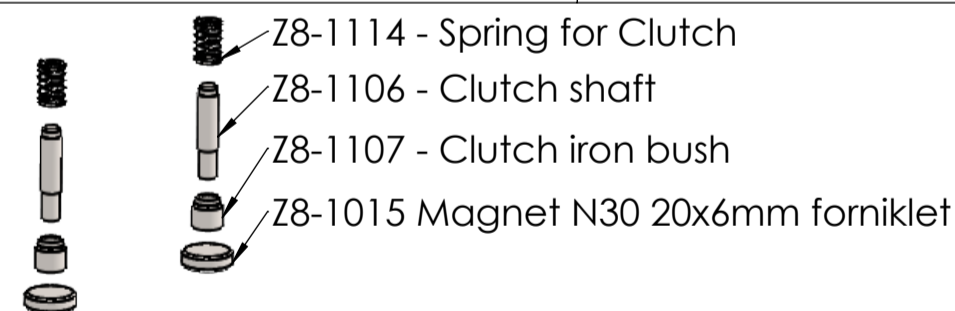
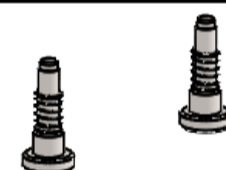

DU-DD1-RF
Rudder feedback bracket for external rudder feedback

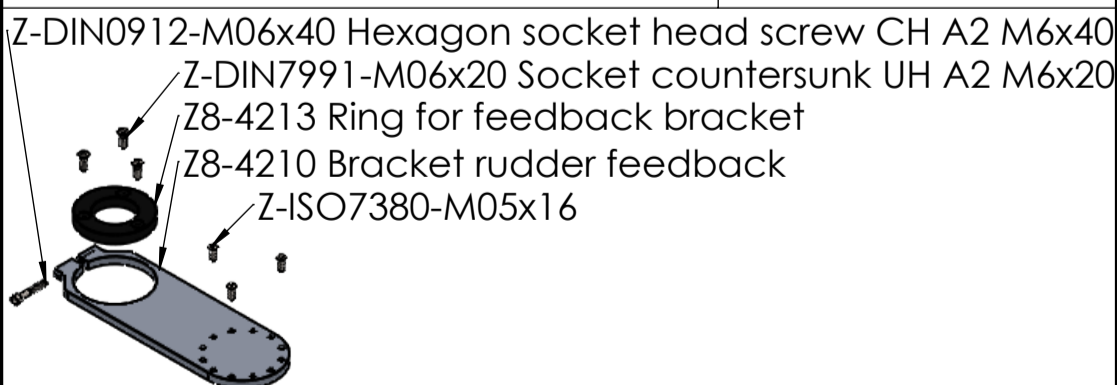

DU-DD1-RFB
Jefa Integrated rudder feedback unit

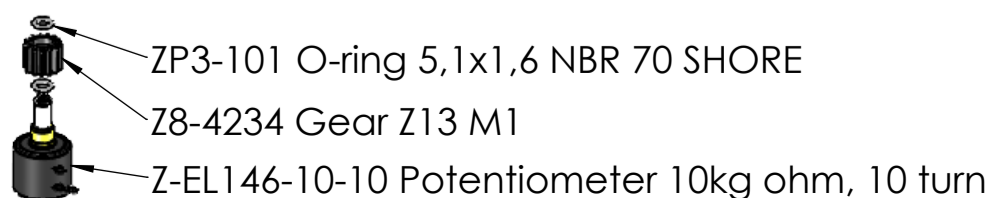

DU-COSET-12
Complete clutch set with 12V coils

